



# SS-75

## FOOD SERVICE WASTE DISPOSER

InSinkErator provides the hospitality industry with a range of Food Service disposers to suit the smallest to largest kitchen. Whether you are catering for 50 to 2500 people, there is a solution for your kitchen. InSinkErator's superior construction, faster operation and shorter grinding time will reduce stress, noise and waste scraps in your workspace.

### Features

- Suitable for medium commercial operations. Approximately 150 people per meal.
- 0.75HP, high torque induction motor
- Stainless steel shredder ring for increased grinding efficiency.
- Stainless steel rotating shredder.
- Cast stainless 360° swivel lugs, stainless steel grind chamber.
- Cast nickel chrome cutting elements
- Extra-large stainless steel grind chamber for extra durability.
- Stainless steel construction
- Automatic reversing action.
- Standard Quiet Sound Reduction System.
- 1 year warranty

### Dimensions (mm)

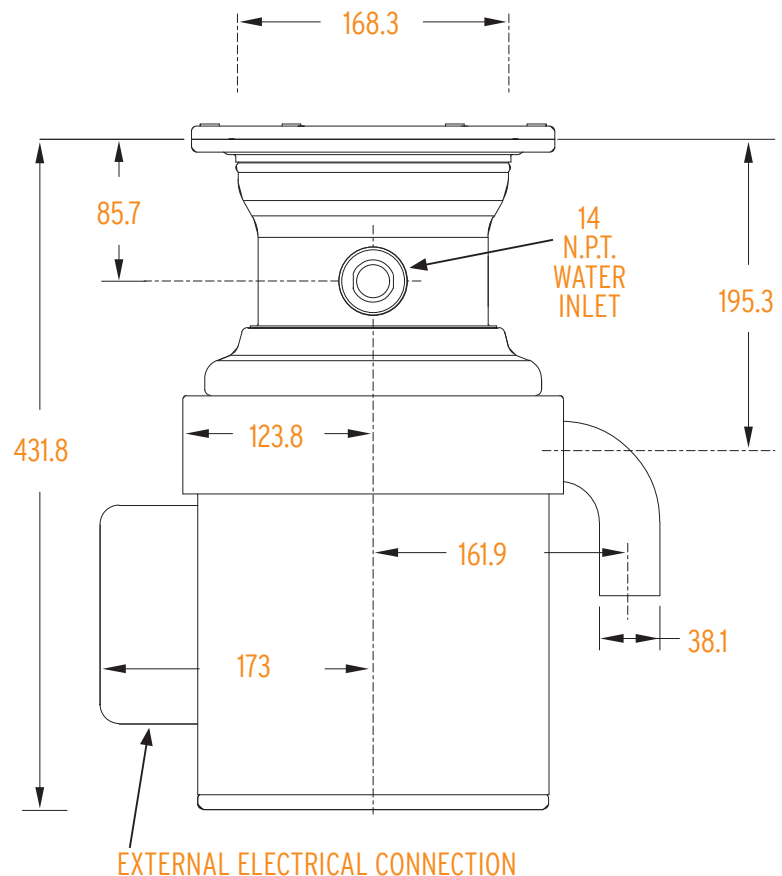

### Specifications

Type of Feed	Continuous
On/Off	Wall Switch
Power Supply	Single or Three Phase
Horsepower	0.75
Volts (V)	240V or 400V
Hertz (Hz)	50
RPM	1425
Lubrication	Self Lubricating
Unit Finish	Stainless Steel and chrome
Overall Height	432mm
Shipping Weight	20kg (approx)

InSinkErator reserves the right to change product specifications without prior notice.

For more information contact Parex Industries Limited  
on Tel: 0800 200 510 or email [info@parex.co.nz](mailto:info@parex.co.nz)

[www.insinkerator.co.nz](http://www.insinkerator.co.nz)

