

HC900

NEAR-BOILING + COLD FILTERED WATER TAP

The InSinkErator HC900 Instant Hot Water Tap dispenses boiling filtered water from an easily installed under-sink hot water tank, as well as filtered drinking water.

The unit produces the perfect temperature for making hot drinks, speeding up the preparation of pasta or vegetables, cleaning dishes and a host of other kitchen tasks.

FEATURES & SPECIFICATIONS

- Boiling (98°C) filtered water, and filter cold water.
- Safe, filtered hot or cold drinking water.
- Child-Safe spring loaded hot water lever.
- Tap insulated from heat.
- Tap available in Chrome.
- Gentle touch, two lever dispenser.
- Tap mounted on either the kitchen work surface or sink. (35mm-38mm drilled hole required in the bench-top)
- Reduces chlorine, lead, and other unpleasant tastes, chemicals and odours from the water.
- Easy to install 2.5 litre stainless steel tank fitted under sink.
- Plugs directly into 240v electrical socket close to appliance.
- Adjustable temperature display on tank.
- Shut-off valve in filter head automatically stops water flow.
- Required supply pressure: 172–862 kPa (1.7–8.6 bar) (25–125 psi)
- Easy to replace filter.
- In-Home Parts and Service Warranty – Residential Only
 - Tank - 2-Year Warranty
 - Filtration System - 1-Year-Warranty (excluding replacement filter cartridge)



TAP FINISHES

CHROME

TECHNICAL DIAGRAM & DIMENSIONS

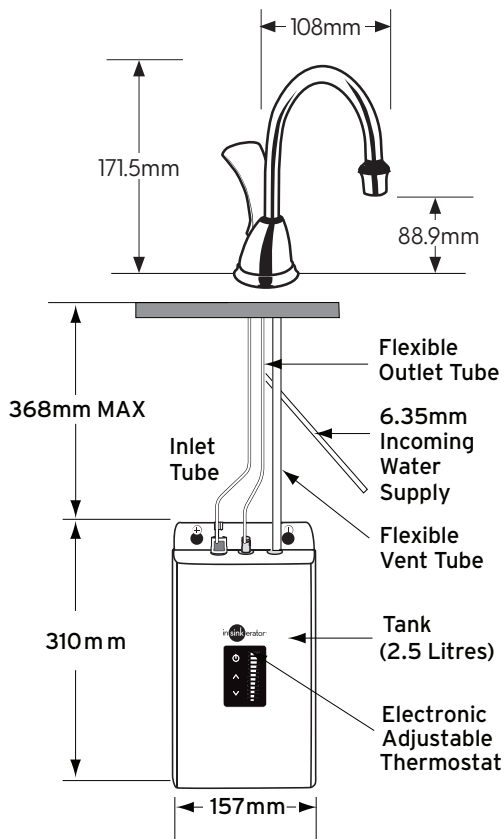

Unit Depth 206mm MAX



EASY TO INSTALL
UNDER SINK TANK
& WATER FILTER

insinkerator.co.nz

For more information contact Parex Industries Limited on Tel: 0800 200 510 or email: info.parex@emerson.com

InSinkErator reserves the right to change product specifications without prior notice.

in sink erator[®]
hottap[™]