

SEPTIC2000

FOOD WASTE DISPOSER

The SEPTIC2000 with its three stage grind technology is perfect for use with a properly sized septic tank. Soundseal™ plus, makes it our quietest model. Don't worry about what you can and can't grind. The SEPTIC2000 grinds it all!

FEATURES



Dura-Drive™ Motor

The InSinkErator Dura-Drive motor is one of the most powerful and reliable on the market.



Built-In Air Switch

All InSinkErator's use air to turn the disposer on and off, making it safe around electricity.



Multigrind Plus™ 3 Stage Grinding

MultiGrind Plus™ 3 Stage Stainless Grinding System with Auto Reverse Action. This grinds the food waste into tiny particles that can easily be broken down in a septic system.



Soundseal Plus™ Noise Reduction

Makes the SEPTIC2000 the quietest on the market.



Largest Stainless Steel 1180ml Grind Chamber

Largest capacity of any domestic disposer on the market.



Quicklock™ Sink Mount

Makes it easy to install into the sink, and come with all models.



Made In The USA



10 Year Warranty

The SEPTIC 2000 comes with a 10 year in-home warranty.



SPECIFICATIONS

Type of Feed	Continuous	Sound Technology	Anti-Vibration Mounting Technology and Tailpipe
On/Off	Control Wall Switch or Built-In Air Switch		Quiet Sink Baffle
Power Supply	Single Phase	Plug	Multi-Layer Sound Insulation
Reversing	Auto-Reverse Grind System		Stainless Steel Strainer Basket and Plug
Time Rating	Intermittent	Grind Chamber Capacity	1180 ml
Lubrication	Permanently Lubricated Upper & Lower Bearings	Motor Protection	Manual Reset Overload
Shipping Weight	11.6 kg (Approx.)	Average Water Usage	Approximately 4.0 L per Person per Day
Unit Finish	Stainless Steel Light Grey TEN-1706	Average Electrical Usage	3-4 KWH per Annum
Overall Height	344 mm	Drain Connection	1-1/2" (3.81 cm) Anti-Vibration (Hose Clamp)
Grind Technology	3-Stage Grind Technology Power Booster Circuit with Microprocessor	Dishwasher Connection	Yes
Volts/Hz	220-240V, 50 Hz	HP	.75
		RPM	1425

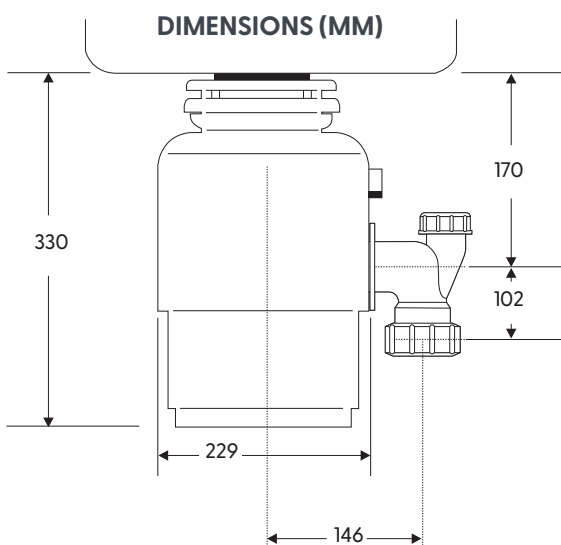

insinkerator.co.nz

For more information contact Parex Industries Limited on Tel: 0800 200 510 or email: info.parex@emerson.com

InSinkErator reserves the right to change product specifications without prior notice. The disposer described in this leaflet is for household use; usage in commercial situations is not covered by

