

SS-300

FOOD WASTE DISPOSER

InSinkErator provides the hospitality industry with a range of Food Service disposers to suit the smallest to largest kitchen. Whether you are catering for 50 to 2500 people, there is a solution for your kitchen. InSinkErator's superior construction, faster operation and shorter grinding time will reduce stress, noise and waste scraps in your workspace.

FEATURES

Designed for large establishments such as banquet facilities, hospitals, universities and military facilities.

- Suitable for large commercial operations. Approximately 750 people per meal
- 3.0HP, high torque induction motor
- Stainless steel shredder ring for increased grinding efficiency
- Stainless steel rotating shredder
- Cast stainless 360° swivel lugs, stainless steel grind chamber
- Cast nickel chrome cutting elements
- Extra-large stainless steel grind chamber for extra durability
- Stainless steel construction
- Automatic reversing action
- Standard Quiet Sound Reduction System
- Legs supplied factory installed
- 1 year warranty

DIMENSIONS (MM)

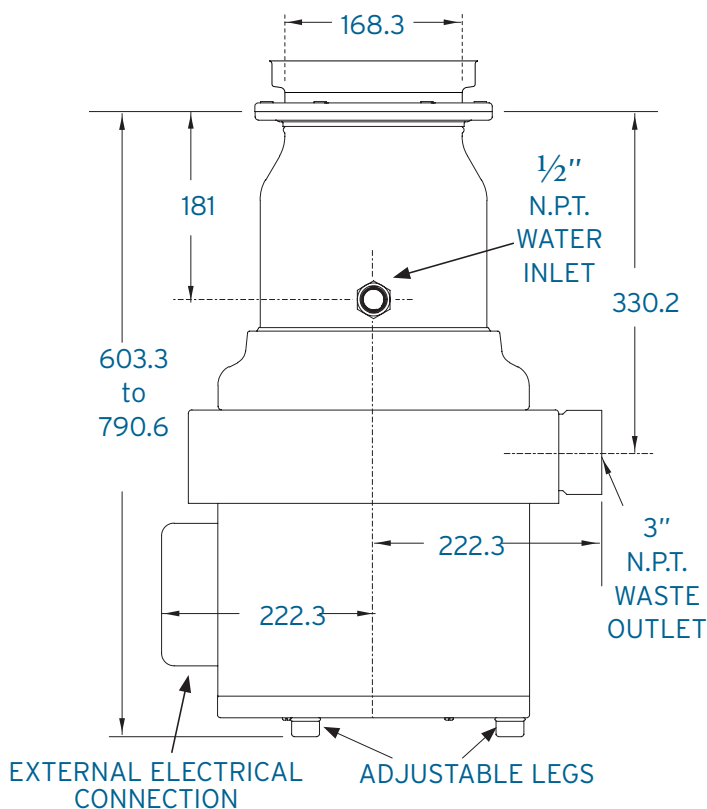

SPECIFICATIONS

Type of Feed	Continuous
On/Off	Wall Switch
Power Supply	3 Phase
Horsepower	3
Volts (V)	460V
Hertz (Hz)	50
RPM	1425
Lubrication	Self Lubricating
Unit Finish	Stainless Steel and Chrome
Overall Height	790mm
Shipping Weight	51kg
Waste Outlet	3"

insinkerator.co.nz

For more information contact Parex Industries Limited
on Tel: 0800 200 510 or email info.parex@whirlpool.com

InSinkErator reserves the right to change product specifications without prior notice.

in sink erator[®]

