

# SS-100

## FOOD WASTE DISPOSER

InSinkEerator provides the hospitality industry with a range of Food Service disposers to suit the smallest to largest kitchen. Whether you are catering for 50 to 2500 people, there is a solution for your kitchen. InSinkEerator's superior construction, faster operation and shorter grinding time will reduce stress, noise and waste scraps in your workspace.

### FEATURES

Designed for small food service establishments such as restaurants and assisted living facilities.

- Suitable for large commercial operations  
Approximately 200 people per meal
- 1 HP, high torque induction motor
- Quick-Lock® mounting assembly for faster, easier installation
- Stainless steel shredder ring for increased grinding efficiency
- Stainless steel rotating shredder
- Cast stainless 360° swivel lugs, stainless steel grind chamber & elements
- Extra-large stainless steel grind chamber for extra durability
- Stainless steel construction
- Automatic reversing action
- Standard Quiet Sound Reduction System
- 1 year warranty

### DIMENSIONS (MM)

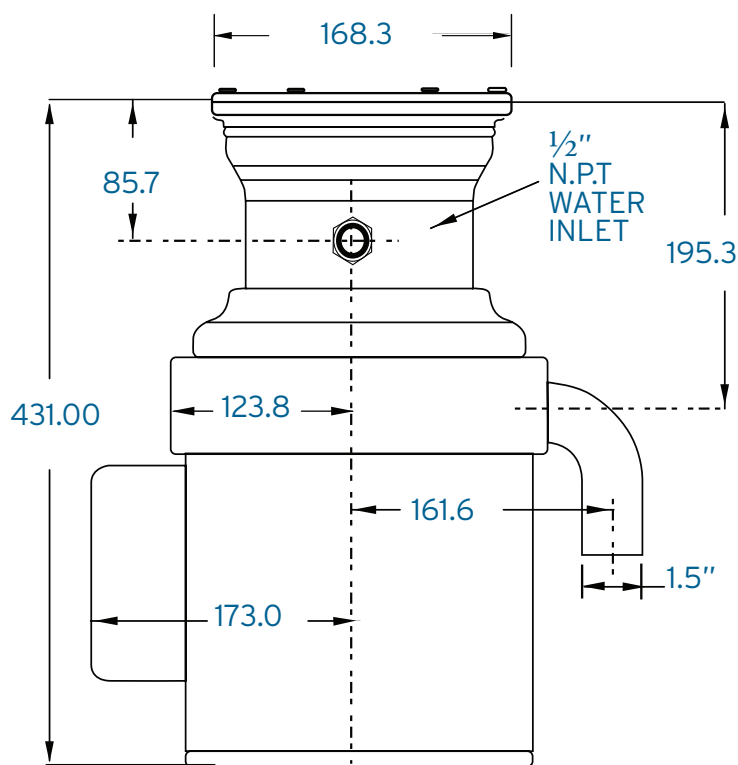

### SPECIFICATIONS

Type of Feed	Continuous
On/Off	Wall Switch
Power Supply	Single Phase
Horsepower	1
Volts (V)	230V
Hertz (Hz)	50
RPM	1425
Lubrication	Self Lubricating
Unit Finish	Stainless Steel and Chrome
Overall Height	431mm
Shipping Weight	23kg
Waste Outlet	1.5"

**insinkerator.co.nz**

For more information contact Parex Industries Limited  
on Tel: 0800 200 510 or email [info.parex@whirlpool.com](mailto:info.parex@whirlpool.com)

InSinkEerator reserves the right to change product specifications without prior notice.

**in sink erator**®