

# LC-50H

## FOOD WASTE DISPOSER

InSinkErator provides the hospitality industry with a range of Food Service disposers to suit the smallest to largest kitchen. Whether you are catering for 50 to 2500 people, there is a solution for your kitchen. InSinkErator's superior construction, faster operation and shorter grinding time will reduce stress, noise and waste scraps in your workspace.

### FEATURES

Designed for small food service establishments such as restaurants and assisted living facilities

- Suitable for small commercial operations  
Approximately 100 people per meal
- 0.5HP, high torque induction motor
- Quick-Lock® mounting assembly for faster, easier installation
- Stainless steel shredder ring for increased grinding efficiency
- Stainless steel rotating shredder
- Cast stainless 360° swivel lugs, stainless steel grind chamber & elements
- Extra-large stainless steel grind chamber for extra durability
- Stainless steel construction
- Automatic reversing action
- Standard Quiet Sound Reduction System
- 1 year warranty



### SPECIFICATIONS

|                 |                            |
|-----------------|----------------------------|
| Type of Feed    | Continuous                 |
| On/Off          | Wall Switch                |
| Power Supply    | Single Phase               |
| Horsepower      | 0.50                       |
| Volts (V)       | 240V                       |
| Hertz (Hz)      | 50                         |
| RPM             | 1425                       |
| Lubrication     | Self Lubricating           |
| Unit Finish     | Stainless Steel and Chrome |
| Overall Height  | 362mm                      |
| Shipping Weight | 16kg                       |
| Waste Outlet    | 1.5"                       |

### DIMENSIONS (MM)

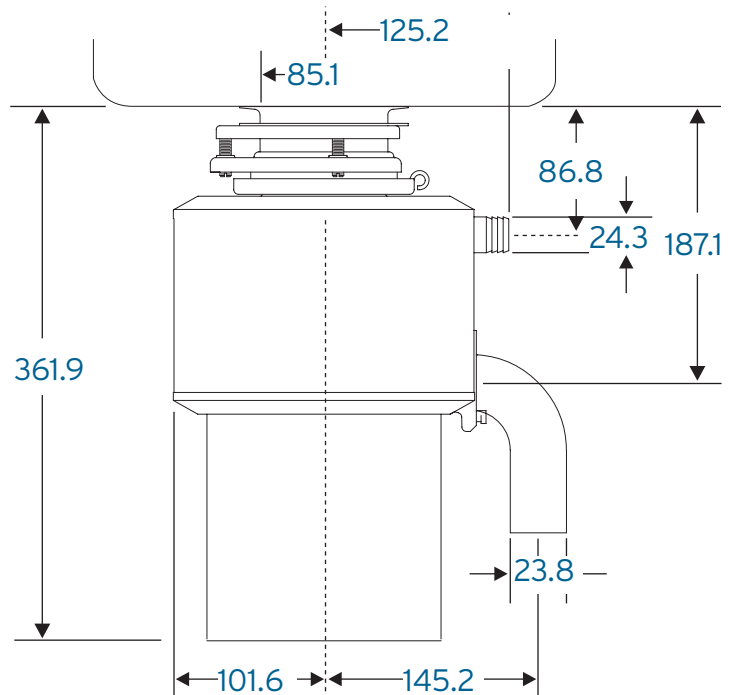

NOTE: Plumb 38.1 mm waste line to prevent standing water in disposer motor housing.

**insinkerator.co.nz**

For more information contact Parex Industries Limited  
on Tel: 0800 200 510 or email [info.parex@whirlpool.com](mailto:info.parex@whirlpool.com)

InSinkErator reserves the right to change product specifications without prior notice.

**in sink erator®**